

ULAC with AC Motor

For industrial use – cooling capacity up to 400 HP



The ULAC oil cooler with AC motor is optimized for use in the industrial sector. Together with a wide range of accessories, the ULAC cooler is suitable for installation in most applications and environments.

- **Optimized design with right choice of materials and components ensures a reliable and long lasting cooler with low service and maintenance costs.**
- **Compact design resulting in lighter weight unit yet with higher cooling capacity and lower pressure drop.**
- **Easy to maintain and easy to retrofit into many applications.**
- **Quiet fan design due to optimization of material and blade design.**
- **AC motor – NEMA three phase motors are standard. Wide range of operating voltages and frequencies available.**
- **Cooler core with low pressure drop and high cooling capacity.**

ULAC Cooling Performance

The cooling capacity curves are based on an ETD (Entering Temperature Difference) of 1 °F. For example, oil temperature of 140 °F and air temperature of 70 °F yields a temperature difference of 70 °F. Multiply the number from the cooling graphs corresponding to the specific flow rate by the ETD for the particular application to get the total heat duty.

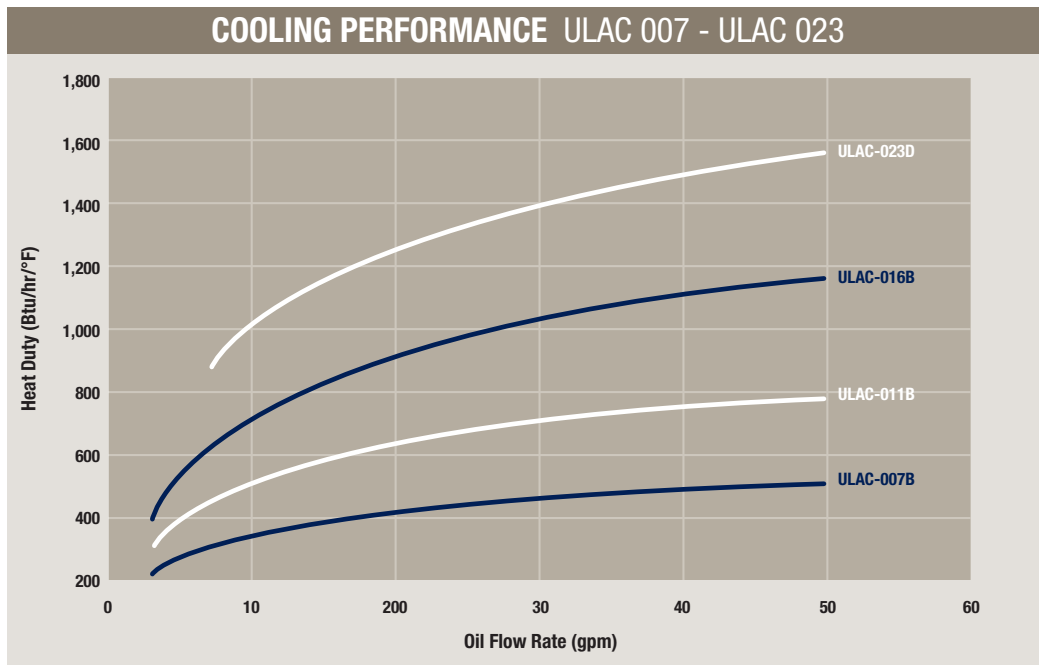

Cooling capacity tolerance ± 10%.

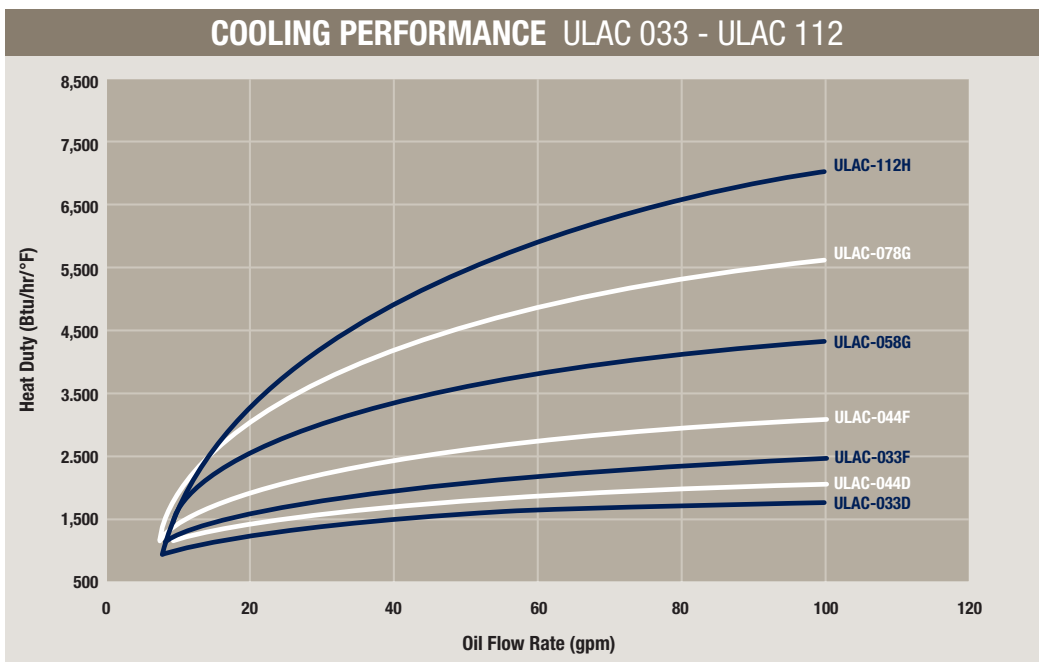

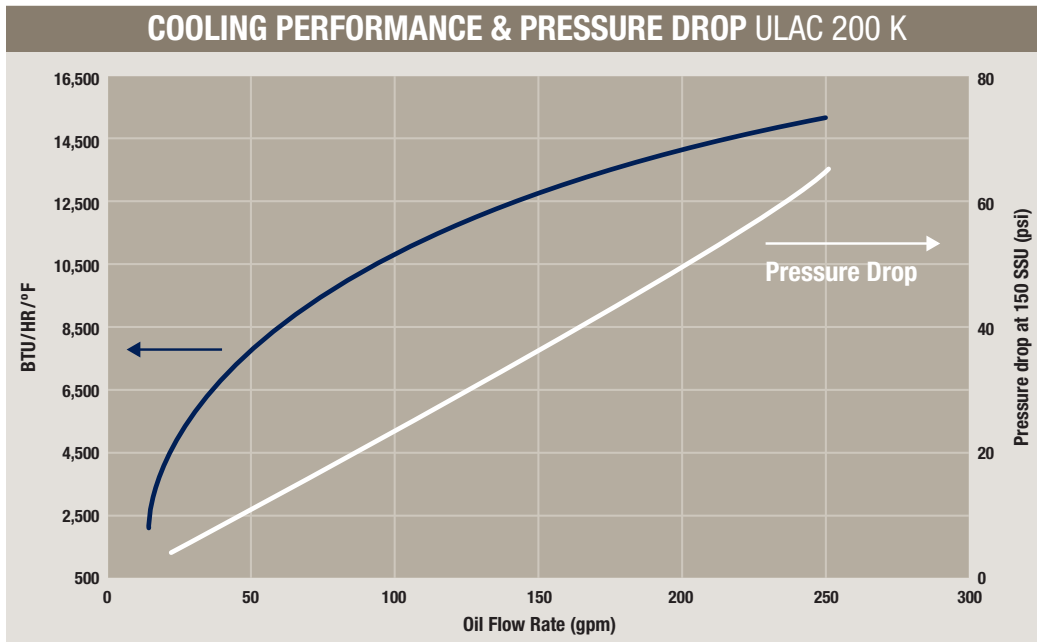

Cooling capacity tolerance $\pm 10\%$.

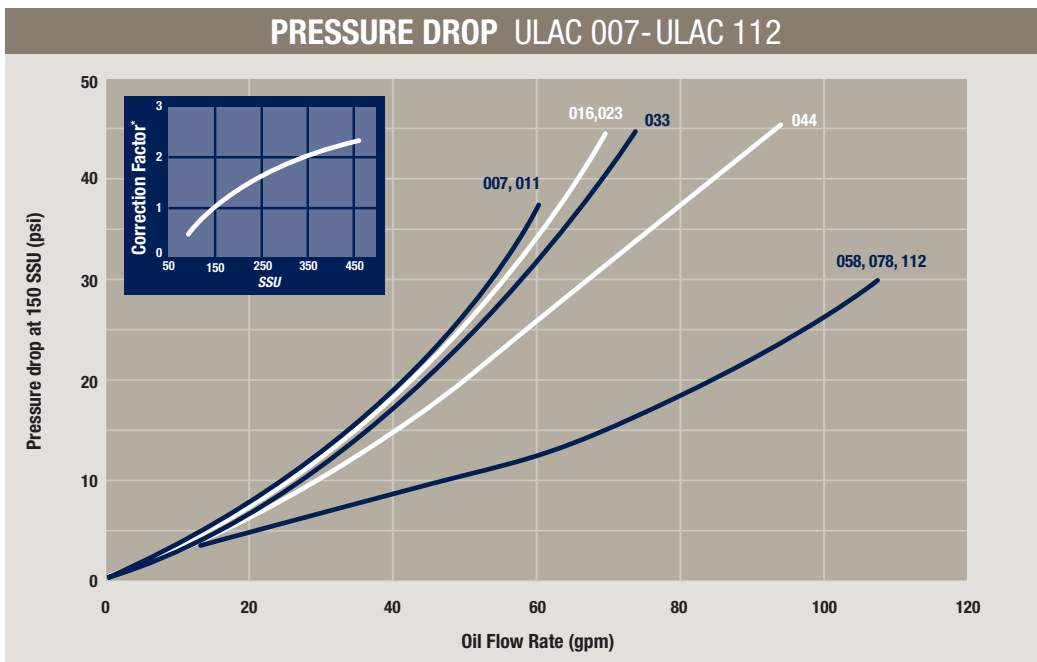

* Pressure Drop Correction Factor for other viscosities.

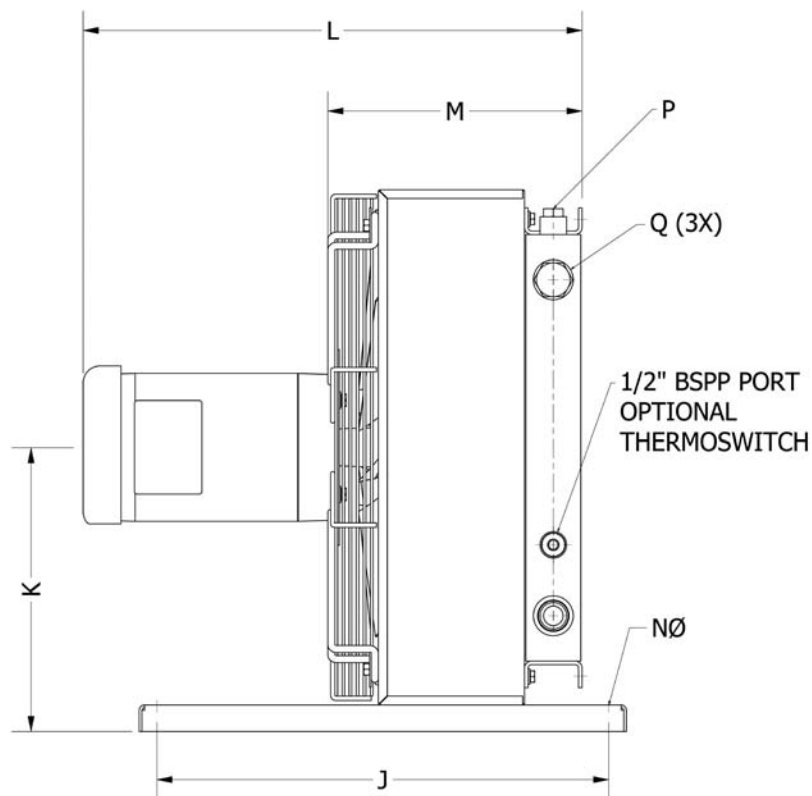

TYPE	Acoustic Pressure Level <i>L_{pA} dB(A) 3 Ft. *</i>	No. Of Poles/ Capacity <i>HP</i>	Weight <i>Lbs. (Approx.)</i>	P <i>SAE O-Ring</i>	Q <i>SAE O-Ring Boss</i>
ULAC 007B	69	4/0.5	33	1/2" (#8)	1" (#16)
ULAC 011B	71	4/0.5	44	1/2" (#8)	1" (#16)
ULAC 016B	74	4/0.5	53	1/2" (#8)	1" (#16)
ULAC 023D	81	4/1	79	1/2" (#8)	1" (#16)
ULAC 033D	82	4/1	115	1/2" (#8)	1 1/4" (#20)
ULAC 033F	86	4/3	170	1/2" (#8)	1 1/4" (#20)
ULAC 044D	83	4/1	143	1/2" (#8)	1 1/4" (#20)
ULAC 044F	87	4/3	197	1/2" (#8)	1 1/4" (#20)
ULAC 058G	90	4/5	264	3/4" (#12)	1 1/2" (#24)
ULAC 078G	92	4/5	434	3/4" (#12)	1 1/2" (#24)
ULAC 112H	96	4/7.5	542	3/4" (#12)	1 1/2" (#24)
ULAC 200K	93	6/15	1,030	NA	CODE 61 SAE 2" FLANGE

*Noise level tolerance ± 3 dB(A).

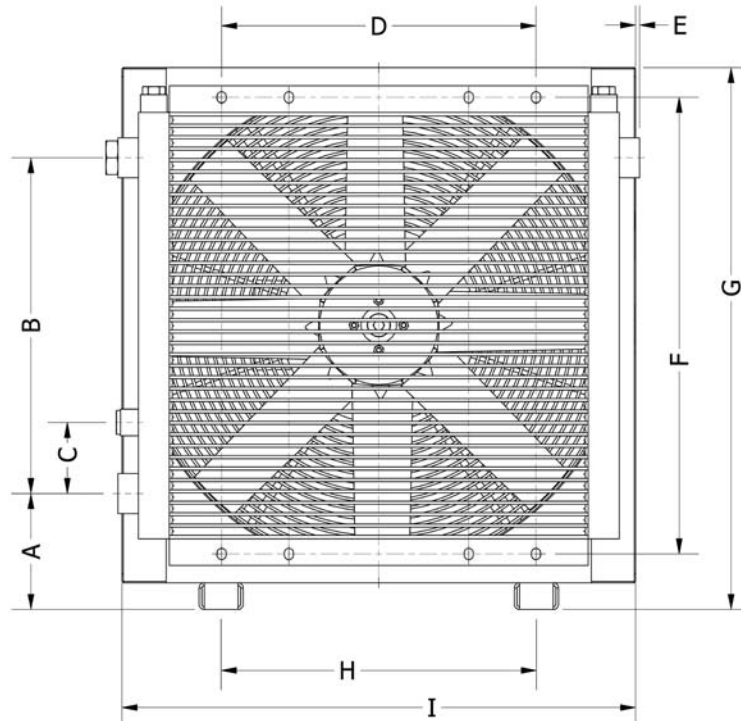

TYPE	A	B	C	D	E	F	G	H	I	J	K	L	M	N \emptyset
ULAC 007B	5.2	6.3	3.2	8.0	0.24	11.7	15.6	8.0	14.4	20.1	8.4	19.8	8.8	0.35
ULAC 011B	5.4	9.0	3.2	8.0	0.12	14.3	18.5	8.0	17.3	20.1	9.8	20.8	9.8	0.35
ULAC 016B	5.2	11.7	3.2	8.0	0.28	17.0	20.7	8.0	19.5	20.1	10.9	21.6	10.7	0.35
ULAC 023D	5.2	14.9	3.2	14.0	0.20	20.2	24.0	14.0	22.8	20.1	12.6	22.2	11.3	0.35
ULAC 033D	5.2	19.1	3.2	14.0	NA	24.5	28.4	14.0	27.2	20.1	14.8	23.1	12.5	0.35
ULAC 033F	5.2	19.1	3.2	14.0	NA	24.5	28.4	14.0	27.2	24.0	14.8	25.6	12.5	0.55
ULAC 044D	4.6	26.1	3.2	14.0	NA	31.5	34.1	14.0	27.2	20.1	17.6	24.1	13.3	0.35
ULAC 044F	4.6	26.1	3.2	14.0	NA	31.5	34.1	14.0	27.2	24.0	18.3	26.6	13.5	0.55
ULAC 058G	5.2	26.1	3.2	20.0	NA	31.5	35.4	20.0	34.2	24.0	18.3	29.9	15.2	0.55
ULAC 078G	5.2	32.3	3.9	26.8	NA	38.9	41.4	20.4	40.2	35.4	21.1	30.9	16.2	0.55
ULAC 112H	5.1	38.8	3.9	31.1	0.14	45.4	47.8	23.6	46.7	35.4	24.4	31.9	17.2	0.55
ULAC 200K	7.2	50.9	5.0	49.6	1.2	61.0	64.2	55.9	59.4	35.4	32.7	41.5	18.7	0.71

All dimensions listed above are in inches.

Order Key for ULAC Oil Coolers

All positions must be filled in when ordering.

EXAMPLE:					
ULAC	-	007B	- M	- 100	- SA
Series		Model	Motor Type	Thermoswitch	Core Bypass
1		2	3	4	5
1. OIL COOLER SERIES WITH AC MOTOR; ULAC					
2. COOLER SIZE/MODEL					
007B, 011B, 016B, 023D, 033F, 033D, 044F, 044D, 058G, 078G, 112H and 200K.					
3. MOTOR TYPE					
No motor					= W
Three-phase 190/380V 50 Hz, 208-230/460V 60 Hz					= M*
Three-phase 208-230/460V 60 Hz					= N
Three-phase 230/460V 60 Hz					= P
Three-phase 575V 60 Hz					= Q
Single-phase 115/230V 60 Hz					= R
Single-phase 230 V 60 Hz					= S
Explosion proof, Division 1, Class 1 Group D, Class II Group F & G, T3C					= X
Not listed, consult Accumulator and Cooler Division					= Z
*The M-motor is our standard motor sizes 1 HP and lower. The performance at 50 HZ will be reduced by approximately 10%					
4. THERMOSWITCH					
No thermoswitch					= 000
100 °F					= 100
120 °F					= 120
140 °F					= 140
160 °F					= 160
175 °F					= 175
195 °F					= 195
Not listed, consult Accumulator and Cooler Division					= ZZZ
5. CORE BYPASS*					
No Bypass					= SW
20 psi External Hose Bypass (standard option)					= SA
65 psi External Hose Bypass (standard option)					= SB
30 psi External Tube Bypass					= SG
75 psi External Tube Bypass					= SH
120 psi External Tube Bypass					= SJ
120 °F External Thermo-Bypass					= SM
140 °F External Thermo-Bypass					= SN
160 °F External Thermo-Bypass					= SP
195 °F External Thermo-Bypass					= SQ
Full Flow External Bypass					= SF
*The standard cores are single pass. Two pass cores and other options available upon request, please consult Accumulator and Cooler Division.					

Technical Specifications

FLUID COMBINATIONS	
Mineral oil	
Oil/water emulsion	
Water glycol	
Phosphate ester	
MATERIAL	
Cooler core	Aluminum
Fan blades/hub	Glass fiber reinforced polypropylene/Aluminum
Fan housing	Steel
Fan guard	Steel
Other parts	Steel
Surface treatment	Electrostatically powder-coated
COOLER CORE	
Maximum static working pressure	300 psi
Dynamic working pressure	200 psi*
Heat transfer tolerance	± 6 %
Maximum oil inlet temperature	250 °F
*Tested in accordance with ISO/DIS 10771-1	
COOLING CAPACITY CURVES	
Cooling capacity curves are based on testing in accordance with EN1048 with ISO VG 46.	
CONTACT PARKER FOR ADVICE ON	
Oil temperatures > 250 °F	
Oil viscosity > 100 cSt / 500 SSU	
Aggressive environments	
Environments with heavy airborne particulates	
High-altitude locations	



The information in this brochure is subject to change without prior notice.