

ULOC Cooling System

For industrial use – cooling capacity up to 60 HP



The ULOC cooling system with three-phase AC motor is optimized for use in the industrial sector. The system is supplied ready for installation. An integrated circulation pump makes it possible to cool and treat the oil in a separate circuit – offline cooling. Together with a wide range of accessories, the ULOC cooling system is suitable for installation in most applications and environments.

- **Optimized design with right choice of materials and components ensures a reliable and long lasting cooler with low service and maintenance costs.**
- **Integrated circulation pump produces and even flow with low pressure pulsations.**
- **Easy to maintain and easy to retrofit in many applications.**
- **Compact design and low weight.**
- **Quiet fan and fan motor.**
- **Cooler core with low pressure drop and high cooling capacity.**

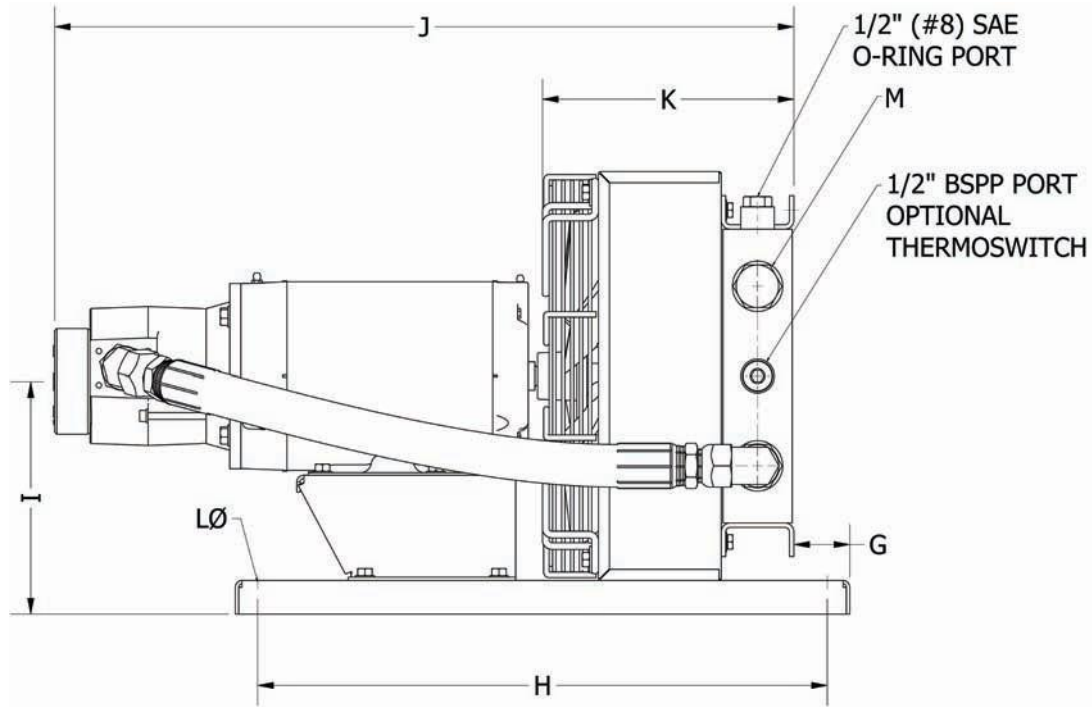

TYPE	Nom. Oil Flow Rate (gpm)	Cooling Capacity at 50 °F ETD (Btu/hr)	Cooling Capacity Btu/hr°F	Acoustic Pressure Level LpA dB(A) 3 Ft.*	Motor Capacity / No. Of Poles HP	Motor
ULOC 007D - A	6.3	15,500	310	71	1/4	1-4-143TC
ULOC 007D - B	12.7	19,000	380	71	1/4	1-4-143TC
ULOC 007E - C	19.0	21,000	420	72	2/4	2-4-145TC
ULOC 007E - D	25.4	22,500	450	72	2/4	2-4-145TC
ULOC 011D - A	6.3	24,000	480	74	1/4	1-4-143TC
ULOC 011D - B	12.7	28,500	570	74	1/4	1-4-143TC
ULOC 011E - C	19.0	32,000	640	74	2/4	2-4-145TC
ULOC 011E - D	25.4	34,500	690	74	2/4	2-4-145TC
ULOC 016E - A	6.3	33,500	670	78	2/4	2-4-145TC
ULOC 016E - B	12.7	41,000	820	78	2/4	2-4-145TC
ULOC 016E - C	19.0	47,000	940	78	2/4	2-4-145TC
ULOC 016E - D	25.4	50,000	1,000	78	2/4	2-4-145TC
ULOC 023F - B	12.7	60,000	1,200	82	3/4	3-4-182TC
ULOC 023F - C	19.0	65,000	1,300	82	3/4	3-4-182TC
ULOC 023F - D	25.4	70,000	1,400	82	3/4	3-4-182TC
ULOC 033G - C	19.0	80,000	1,600	87	5/4	5-4-182TC
ULOC 033G - D	25.4	90,000	1,800	87	5/4	5-4-184TC
ULOC 044G - C	19.0	95,000	1,900	88	5/4	5-4-182TC
ULOC 044G - D	25.4	105,000	2,100	88	5/4	5-4-182TC

Electric motors specified are calculated for max. Working pressure 90 psi at 125 cSt and 50 Hz, 60 psi at 125 cSt and 60 Hz. If you require higher pressure, please contact us for a choice of motors with a higher output.
 *Noise level tolerance ± 3 dB(A).

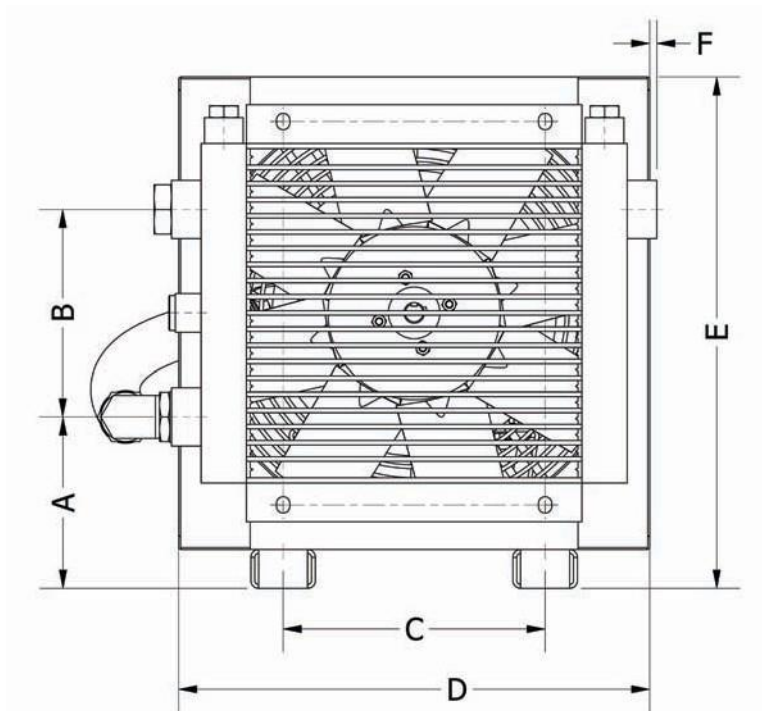

TYPE	A	B	C	D	E	F	G	H	I	J	K	Lø	M SAE O-Ring Boss*
ULOC 007D - A	5.2	6.3	8.0	14.4	15.6	0.2	2.0	20.1	8.5	26.1	8.9	0.35	1" (#16)
ULOC 007D - B	5.2	6.3	8.0	14.4	15.6	0.2	2.0	20.1	8.5	26.6	8.9	0.35	1" (#16)
ULOC 007E - C	5.2	6.3	8.0	14.4	15.6	0.2	2.0	20.1	8.5	27.1	8.9	0.35	1" (#16)
ULOC 007E - D	5.2	6.3	8.0	14.4	15.6	0.2	2.0	20.1	8.5	27.6	8.9	0.35	1" (#16)
ULOC 011D - A	5.3	9.0	8.0	17.3	18.5	0.1	2.0	20.1	9.9	27.0	9.9	0.35	1" (#16)
ULOC 011D - B	5.3	9.0	8.0	17.3	18.5	0.1	2.0	20.1	9.6	27.4	9.8	0.35	1" (#16)
ULOC 011E - C	5.4	9.0	8.0	17.3	18.5	0.1	2.0	20.1	9.9	28.0	9.8	0.35	1" (#16)
ULOC 011E - D	5.4	9.0	8.0	17.3	18.5	0.1	2.0	20.1	9.6	28.5	9.8	0.35	1" (#16)
ULOC 016E - A	5.1	11.7	8.0	19.5	20.7	0.3	2.0	20.1	11.0	27.7	10.7	0.35	1" (#16)
ULOC 016E - B	5.1	11.7	8.0	19.5	20.7	0.3	2.0	20.1	11.0	28.2	10.7	0.35	1" (#16)
ULOC 016E - C	5.1	11.7	8.0	19.5	20.7	0.3	2.0	20.1	11.0	28.8	10.7	0.35	1" (#16)
ULOC 016E - D	5.1	11.7	8.0	19.5	20.7	0.3	2.0	20.1	10.7	29.3	10.7	0.35	1" (#16)
ULOC 023F - B	5.2	14.9	14.0	22.8	24.0	0.2	2.0	24.0	12.4	30.7	11.3	0.55	1" (#16)
ULOC 023F - C	5.1	14.9	14.0	22.8	24.0	0.2	2.0	24.0	12.4	31.2	11.3	0.55	1" (#16)
ULOC 023F - D	5.1	14.9	14.0	22.8	24.0	0.2	2.0	24.0	12.4	31.7	11.3	0.55	1" (#16)
ULOC 033G - C	5.2	19.1	14.0	27.2	28.4	-	2.4	24.0	14.6	32.7	12.5	0.55	1¼" (#20)
ULOC 033G - D	5.2	19.1	14.0	27.2	28.4	-	2.4	24.0	14.9	33.2	12.5	0.55	1¼" (#20)
ULOC 044G - C	4.5	26.1	14.0	27.2	34.1	-	2.0	24.0	17.4	33.6	13.5	0.55	1¼" (#20)
ULOC 044G - D	4.5	26.1	14.0	27.2	34.1	-	2.0	24.0	17.4	33.9	13.5	0.55	1¼" (#20)

* Port on the inlet side of the pump is 1½" (#24) SAE O-ring Boss for all models.
All dimensions listed above are in inches.

Order Key for ULOC Cooling Systems

All positions must be filled in when ordering.

EXAMPLE:				
U	L	O	C	SA
Series	Model	Motor Type	Pump Flow Rate	Core Bypass
1	2	3	4	5
1. OIL COOLER SERIES OFFLINE, WITH PUMP; ULOC				
2. COOLER SIZE/MODEL				
007D, 007E, 011D, 011E, 016E, 023F, 033G, 044G				
3. MOTOR TYPE				
No motor				= W
Three phase, 190/380V 50 Hz, 208-230/460V 60Hz				= M
Three phase, 575V 60Hz				= Q
Not listed, consult Accumulator and Cooler Division				= Z
<i>Performance at 50 Hz will be reduced by approximately 10%</i>				
4. PUMP FLOW RATE (GPM)				
6				= A
12				= B
19				= C
25				= D
5. CORE BYPASS*				
No Bypass				= SW
20 psi External Hose Bypass (standard option)				= SA
65 psi External Hose Bypass (standard option)				= SB
30 psi External Tube Bypass				= SG
75 psi External Tube Bypass				= SH
120 psi External Tube Bypass				= SJ
120 °F External Thermo-Bypass				= SM
140 °F External Thermo-Bypass				= SN
160 °F External Thermo-Bypass				= SP
195 °F External Thermo-Bypass				= SQ
<i>*The standard cores are single pass. Two pass cores and other options available upon request, please consult Accumulator and Cooler Division.</i>				

Technical Specifications

COOLER CORE	
Maximum static working pressure	300 psi
Dynamic working pressure	200 psi*
Heat transfer tolerance	± 6 %
Maximum oil inlet temperature	250 °F
<i>* Tested in accordance with ISO/DIS 10771-1</i>	
<ul style="list-style-type: none"> • ULOC is designed primarily for synthetic oils, vegetable oils and mineral oil type HL/HLP in accordance with DIN 51524. Maximum oil temperature 210 °F. • Maximum negative pressure in the inlet line is 6 psi with an oil-filled pump. Maximum pressure on the pump's suction side is 8 psi. • Maximum working pressure for the pump is 150 psi. 	
Heat transfer tolerance	± 6 %
MATERIAL	
Cooler Core	Aluminum
Fan blades/hub	Glass fiber reinforced polypropylene/Aluminum
Fan housing	Steel
Fan guard	Steel
Pump Housing	Aluminum
Other parts	Steel
Surface treatment	Electrostatically powder-coated
CONTACT PARKER FOR ADVICE ON	
Oil temperatures > 250 °F	
Oil viscosity > 100 cSt / 500 SSU	
Aggressive environments	
Environments with heavy airborne particulates	
High-altitude locations	



Bypass Valve



Stone Guard

The information in this brochure is subject to change without prior notice.

